

SPECIFICATION SHEET

LED OBSTRUCTION LIGHT

---2018 VERNON-I

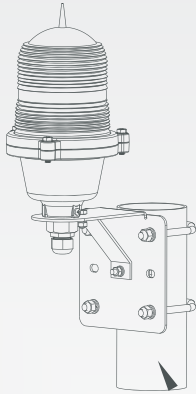

LED BEACON LIGHT

Product Category List:

1. LOW INTENSITY

ARROW	P.
SHEILD.S	P.
SHEILD.D	P.

2. MEDIUM INTENSITY

AXE	P.
COSMOS	P.

3. SOLAR

AXE-SOLAR	P.
COSMOS	P.

4. CONTROL BOX

P.

5. ACCESSORIES

P.

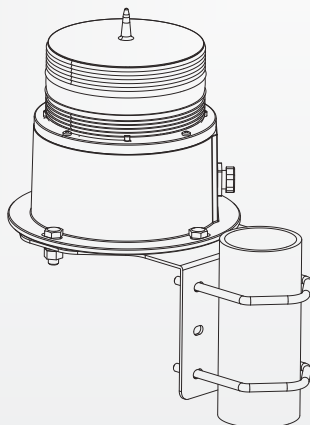
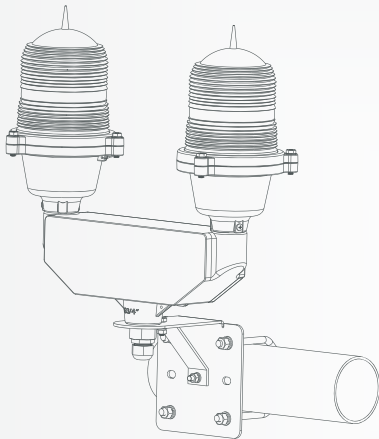

PowerCon usa is a professional supplier in outdoor lighting series , who is specializing both in street lights and garden lights .

and We own a high quality team for LED industrial design, R&D, quality control and marketing. We also have very close business and technician co-operation with many well-know LED lights manufactures in China , to be sure of the best qualified and fashion lights supplying to Customers.

Low Intensity

- **ARROW**
(made by glass diffuser)
- **SHEID**
(made by PC diffuser)

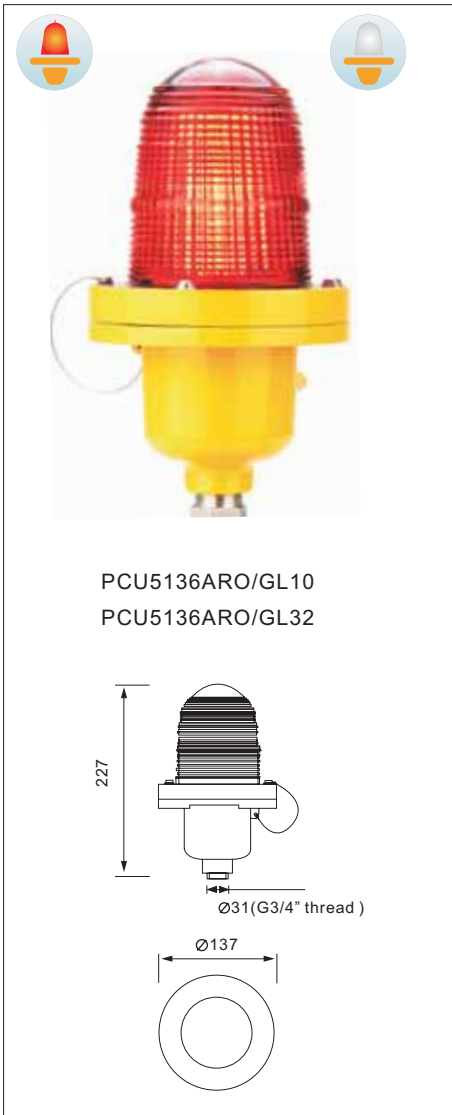

For installation of LED Low Intensity Obstruction light
 Model : PCU5136ARO/GL10 , PCU5137ARO/GL32

PCU5136ARO/GL10
 PCU5136ARO/GL32

DESCRIPTION:

G3/4" mounted type designed for pipe installation. Die casting aluminum body and Prismatic glass as its' diffuser .Yellow outlook color as it's Standard.

(E27 lamp holder with LED corn bulb as its lighting source)

TECHNICAL CHARACTERISTICS:

Type:  G3/4" Mounted Pipe Type
 IP Protection degrees: IP65
 Beam Angle: 360°
 Safety Class : Class-I/III
 Working Temperature : -20°C ~ +65°C

FIXTURE ORDERING INFORMATION

EXAMPLE: PCU137ARO/GL.10.AC.RD.F.

Item No.	Candela	Voltage	LED Color	Flash state	Photosensor
PCU5137ARO/GL	10=10cd	DC12	RD=red	F=Flash	P=Photosensor
	32=32cd	DC24	WT=white	NF=no flash	NP=no photosensor
		DC48	BL=blue		
		AC 85-264	GN=green		

Select appropriate choice from each column as in the following examples .

Item No.: PCU5137ARO/GL10

Item No.: PCU5137ARO/GL32

LEDs: SMD EPISTAR 16LEDs ,3W

LEDs: SMD EPISTAR 16LEDs ,4W

Socket: 1xE27

Socket: 1xE27

Difference in Type-A or Type-B

Box Size/Unit : 55.5*28.5*17.8cm

Gross Weight (kg) : 11.2Kg/6PC

MATERIALS/FINISHES:

Structure material: Die-casting aluminum
 Structure finish: Yellow

Diffuser Material:
 Color Glass



SAMPLE FOR STICK LABELS:

Product Description

LED OBSTRUCTION LIGHT

Features: Flashing & Photosensor	Protection IP65
Power Supply 100-240V AC ,50-60Hz	Power Rate 3W

Product Part #: xxxxxxxx

Stick Label of box & carton

LED OBSTRUCTION LIGHT YOUR LOGO®

Product Part #: xxxxxxxx

Power: 3W	Input: 100-240V AC, 50-60Hz	Protection: IP65
-----------	-----------------------------	------------------

Stick Label of Lamp Body



Broken Pictures

For installation of LED Low Intensity Obstruction light

Model : PCU75137SHD/PC

IP65

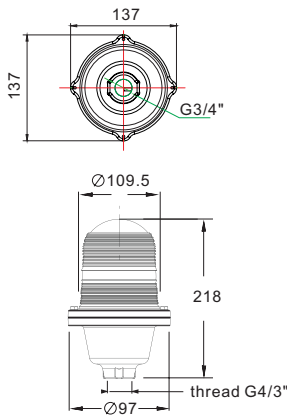
 PCU5137SHD/PC10
 PCU5137SHD/PC32

DESCRIPTION:

G3/4" mounted type designed for pipe installation. Die casting aluminum body and Prismatic anti-shock PC as its' diffuser .Yellow outlook color as it's Standard.

(E27 lamp holder with LED corn bulb as its lighting source)

TECHNICAL CHARACTERISTICS:

 Type:  G3/4" Mounted Pipe Type

IP Protection degrees: IP65

Beam Angle: 360°

Safety Class : Class-I/III

Working Temperature : -20°C ~ +65°C

FIXTURE ORDERING INFORMATION

EXAMPLE: PCU5137SHD/PC.10.AC.RD.F.

Item No.	Candela	Voltage	LED Color	Flash state	Photosensor
PCU5137SHD/PC	10=10cd	DC12	RD=red	F=Flash	P=Photosensor
	32=32cd	DC24	WT=white	NF=no flash	NP=no photosensor
		DC48	BL=blue		
		AC 85-264	GN=green		

Select appropriate choice from each column as in the following examples .

Item No.: PCU5137SHD/PC10

LEDs: SMD2835 16LEDs ,3W

Item No.: PCU5137SHD/PC32

LEDs: SMD2835 16LEDs ,4W

Difference in Type-A or Type-B
Box Size/Unit : 41*38*59cm

Gross Weight (kg) : 7.5Kg/8PC



MATERIALS/FINISHES:
Structure material: Die-casting aluminum

Structure finish: Yellow

Diffuser Material:

Anti-UV PC/Polycarbonate

SAMPLE FOR STICK LABELS:

Product Description	
LED OBSTRUCTION LIGHT	
Features: Flashing & Photosensor	Protection IP67
Power Supply 100-240V AC ,50-60Hz	Power Rate 3W
Product Part #:	xxxxxxx
 	

Stick Label of box & carton

LED OBSTRUCTION LIGHT		YOUR LOGO^o
Product Part #:		xxxxxxx
Power: 3W	Input: 100-240V AC, 50-60Hz	Protection: IP67

Stick Label of Lamp Body

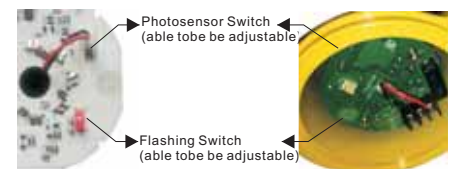

Operation Illustration of Photosensor & Flasing



For installation of LED Low Intensity Obstruction light

Model : PCU5137SHD/PC

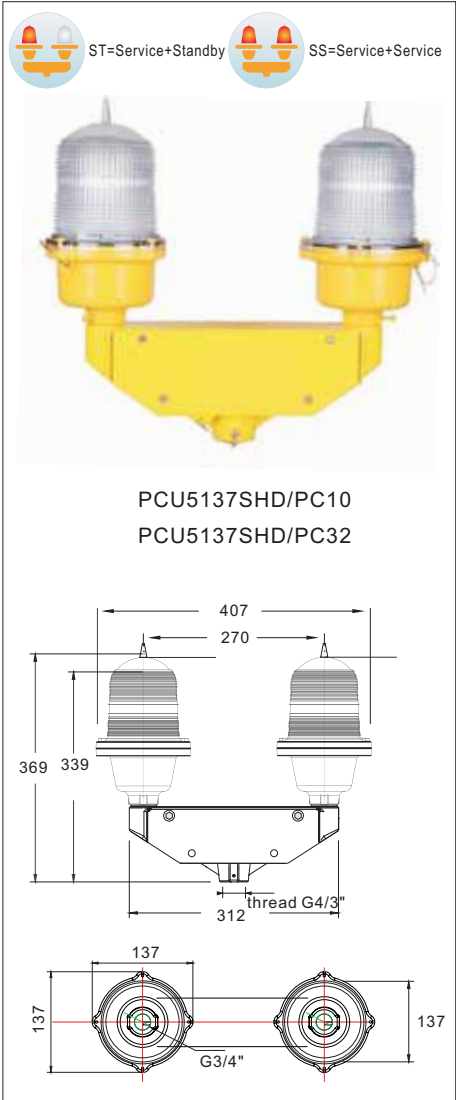
IP65

 PCU5137SHD/PC10
 PCU5137SHD/PC32

DESCRIPTION:

G3/4" mounted type designed for pipe installation. Die casting aluminum body and Prismatic anti-shock PC as its' diffuser .Yellow outlook color as it's Standard.

(E27 lamp holder with LED corn bulb as its lighting source)

TECHNICAL CHARACTERISTICS:

 Type:  G3/4" Mounted Pipe Type
 IP Protection degrees: IP65
 Beam Angle: 360°
 Safety Class : Class-I/III
 Working Temperature : -20°C ~ +65°C

FIXTURE ORDERING INFORMATION
EXAMPLE: PCU5137SHD/PC.10.AC.RD.F.P.S

Item No.	Candela	Voltage	LED Color	Flash state	Photosensor	Service State
PCU5137SHD/PC10	10=10cd	DC12	RD=red	F=Flash	P=Photosensor	ST
	32=32cd	DC24	WT=white	NF=no flash	NP=no photosensor	
		DC48	BL=blue			SS
		AC85-264	GN=green			

Select appropriate choice from each column as in the following examples .

Item No.: PCU5137SHD/PC10

Item No.: PCU5137SHD/PC32

LEDs: SMD2835 2x16LEDs ,2x3W

LEDs: SMD2835 2x16LEDs ,2x4W

Difference in Type-A or Type-B
Box Size/Unit : 48*43*80cm

Gross Weight (kg) : 17Kg/4PC

ST=Service+Standby



SS=Service+Service

MATERIALS/FINISHES:
Structure material: Die-casting aluminum
Structure finish: Yellow

Diffuser Material:
 Anti-UV PC/Polycarbonate

SAMPLE FOR STICK LABELS:

Product Description	
LED OBSTRUCTION LIGHT	
Features: Flashing & Photosensor	Protection IP67
Power Supply 100-240V AC ,50-60Hz	Power Rate 2x3W
Product Part #: xxxxxxx	
	

Stick Label of box & carton

LED OBSTRUCTION LIGHT		YOUR LOGO^o
Product Part #: xxxxxxx		xxxxxxx
Power: 2x3W	Input: 100-240V AC, 50-60Hz	Protection: IP67

Stick Label of Lamp Body

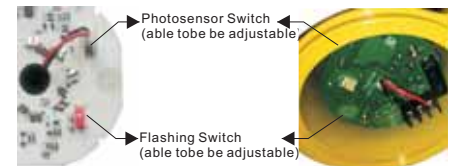

Operation Illustration of Photosensor & Flasing



Medium Intensity

- **AXE**
(made by PC diffuser)
- **SPEAR**
(made by PC diffuser)

For installation of LED Medium Intensity Obstruction light
Model : PCU9160AXE/PC2K

IP67



PCU9160AXE/PC2K

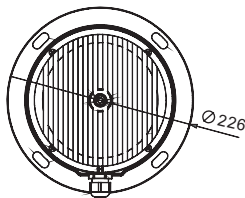
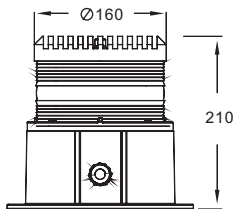

DESCRIPTION:

LED Medium Intensity designed for flange installation. Die casting aluminum body and Prismatic Anti-Shock & anit-UV polyester/PC as its' diffuser .

Yellow outlook color as it's Standard.

TECHNICAL CHARACTERISTICS:

Type: LED Medium Intensity
 IP Protection degrees: IP67
 Beam Angle: 360° horizontal
 Safety Class : Class-I/III
 Working Temperature : -20°C ~ +65°C



FIXTURE ORDERING INFORMATION

EXAMPLE: PCU9160AXE/PC2K.AC.RD.F.P

Item No.	Candela	Voltage	LED Color	Flash state	Photosensor
PCU9160AXE/PC	2K=2000cd	DC12	RD=red	F=Flash	P=Photosensor
		DC24	WT=white	NF=no flash	NP=no photosensor
		DC48	BL=blue		
		AC 85-264	GN=green		

Select appropriate choice from each column as in the following examples .

Item No.: PCU9160AXE/PC2K
 LEDs: OSRAM CP7P 16LEDs ,30W
 Beam Angle: 360° horizontal

Box Size/Unit : 60*29.5*29.5cm
Gross Weight (kg) : 14Kg/4PC



MATERIALS/FINISHES:

Structure material: Die-casting aluminum
 Structure finish: Yellow

Diffuser Material:
 Anti-UV PC/Polycarbonate

INSTALLATION

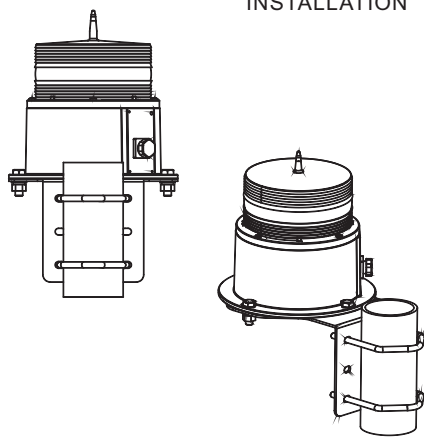

SAMPLE FOR STICK LABELS:

Product Description **YOUR LOGO®**
LED OBSTRUCTION LIGHT

Features: Flashing & Photosensor	Protection IP67
Power Supply 100-240V AC ,50-60Hz	Power Rate 30W

Product Part #: xxxxxxxx

Stick Label of box & carton

LED OBSTRUCTION LIGHT **YOUR LOGO®**
 Product Part #: xxxxxxxx
 Power: 30W | Input: 100-240V AC, 50-60Hz | Protection: IP67

Stick Label of Lamp Body

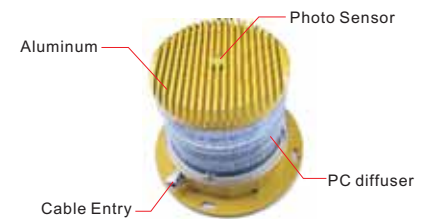

Operation Illustration of Photosensor & Flasing

Solar Series

- AXE-SOLAR
(Medium Intensity)
- COSMOS
(Low Intensity)

For installation of LED-Solar Low Intensity Obstruction light
Model : PCU-SL5155CSM/PC



PCU-SL5155CSM/PC10
PCU-SL5155CSM/PC32

DESCRIPTION:

LED Medium Intensity designed for flange installation. Die casting aluminum body and Prismatic Anti-Shock & anit-UV polyester/PC as its' diffuser . Powered by Solar.

Yellow outlook color as it's Standard.

TECHNICAL CHARACTERISTICS:

Type: LED-Solar Low Intensity
IP/IK Protection degrees: IP67/IK08
Beam Angle: 360° horizontal
Safety Class : Class-III
Working Temperature : -20°C ~ +65°C

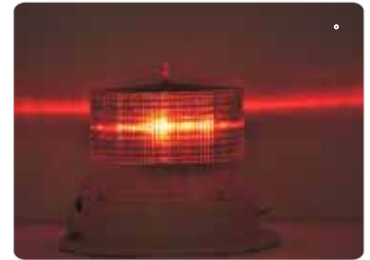

FIXTURE ORDERING INFORMATION
EXAMPLE: PCU-SL5155CSM/PC.10.DC.RD.F

Item No.	Candela	Voltage	LED Color	Flash state	Battery & Solar
PCU-SL5155CSM/PC	10=10cd	DC12	RD=red	F=Flash	8AH/3.6V, LED1.8W
	32=32cd	DC24	WT=white	NF=no flash	8AH/3.6V, LED4.8W
			BL=blue		
			GN=green		

Select appropriate choice from each column as in the following examples .

Item No.: PCU-SL5155CSM/PC10
LEDs: SMD EPISTAR 16LEDs , 1.8W

Item No.: PCU-SL5155CSM/PC32
LEDs: SMD EPISTAR 16LEDs , 4.8W

Box Size/Unit :	60*29.5*29.5cm
Gross Weight (kg) :	11Kg/4PC



MATERIALS/FINISHES:

Structure material: Die-casting aluminum
Structure finish: Yellow

Diffuser Material:
Anti-UV PC/Polycarbonate

SAMPLE FOR STICK LABELS:



Product Description
LED-SOLAR OBSTRUCTION LIGHT

Features: LED & SOLAR	Protection IP67
Power Supply Solar system	Power Rate 1.8W

Product Part #: xxxxxxxx

Stick Label of box & carton

LED-SOLAR OBSTRUCTION LIGHT YOUR LOGO^o
Product Part #: xxxxxxxx

Power:1.8W	Input: Solar System 12V DC	Protection: IP67
------------	----------------------------	------------------

Stick Label of Lamp Body



Operation Illustration of Photosensor & Flasing

For installation of LED-Solar Medium Intensity Obstruction light
Model : PCU-SL9160AXE/PC2K



DESCRIPTION:

LED Medium Intensity designed for flange installation. Die casting aluminum body and Prismatic Anti-Shock & anit-UV polyester/PC as its' diffuser . Powered by Solar.

Yellow outlook color as it's Standard.

TECHNICAL CHARACTERISTICS:

Type: LED-Solar Medium
 IP/IK Protection degrees: IP67/IK08
 Beam Angle: 360° horizontal
 Safety Class : Class-III
 Working Temperature : -20°C ~ +65°C



FIXTURE ORDERING INFORMATION

EXAMPLE: PCU-SL9160AXE/PC.2K.DC.RD.F

Item No.	Candela	Voltage	LED Color	Flash state	Battery
PCU-SL9160AXE/PC	2K=2000cd	DC12	RD=red	F=Flash	12AH/12V
		DC24	WT=white	NF=no flash	Solar Panel
			BL=blue		17.5V/30W
			GN=green		8 days constant working

Select appropriate choice from each column as in the following examples .

PACKING DETAILS- Solar Panel:

Box Size/Unit : 37.5*39*12cm
 Net Weight (Kg) : 1.5kg
 QTY/Carton : 1pc

PACKING DETAILS- Lights:

Box Size/Unit : 48*29.5*29.5cm
 Net Weight (Kg) : 1.3kg
 QTY/Carton : 1pc



MATERIALS/FINISHES:

Structure material: Die-casting aluminum
Structure finish: Yellow

Diffuser Material:
 Anti-UV PC/Polycarbonate

SAMPLE FOR STICK LABELS:

Product Description

LED OBSTRUCTION LIGHT

Features: Flashing & Photosensor	Protection IP67
Power Supply 100-240V AC ,50-60Hz	Power Rate 30W

Product Part #: xxxxxxx

Stick Label of box & carton

LED OBSTRUCTION LIGHT YOUR LOGO[®]

Product Part #: xxxxxxx

Power: 30W	Input: 100-240V AC, 50-60Hz	Protection: IP67
------------	-----------------------------	------------------

Stick Label of Lamp Body



Operation Illustration of Photosensor & Flasing

OBSTRUCTION LIGHT 2018.V1

